



DSRQ-DSRSQ

Variable geometry diffuser on 597x597 mm panel developed for rooms with high ceilings where a long throw and a high induction ratio are required. Made up of a half-housing in which individually or simultaneously adjustable deflectors are fitted (if required) in order to change the direction of the air jet in relation to the thermal conditions required.

DSRQ: Manual blades adjustment

DSRSQ: Simultaneously blades adjustment

TECHNICAL SPECIFICATION AND USAGE LIMIT

INSTALLATION HEIGHT	APPLICATIONS	MAIN BELL MATERIAL	BLADES MATERIAL	SURFACE FINISH	COLOR	FASTENING
up to 16 m	Room cooling and heating	Aluminum	Galvanized Steel	Epoxy powder coating resistant to impact and abrasion	Standard RAL 9010 - glossy RAL 9016 - glossy RAL 9003 - mat	by means of screws positioned on the diffuser neck

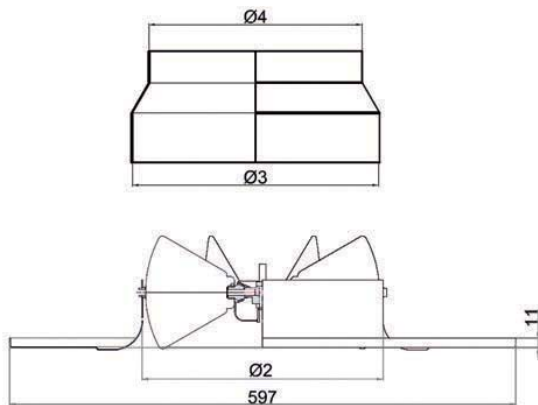

Note:

The upper bell for fixing the DSRQ/DSRSQ models is equipped with an equalizing grid.

GREEN BUILDING

Thanks also to the support of GreenMap, products manufactured by Tecnica srl contribute to obtain the credits of the major international rating systems for sustainable buildings:



LEED

Contributes to credits:
IP, EA, MR



WELL

Contributes to credits:
MATERIALS, COMMUNITY



BREEAM









Contributes to credits:
MAN, WST

For further details about specific contributions to the credits indicated, contact Tecnica Srl

TECHNICAL DATA

Model	Ø 2 [mm]	Ø 3 [mm]	Ø 4 [mm]
DSRQ 250	284	286	248
DSRQ 315	349	352	313
DSRQ 400	433	436	398

APPLICATIONS

								
Residential	Easy Pack	Calculation Method	REACH Certificat	RoHS Certificat	Industry	Building	Air Conditioning	Interior design

Heating function - 45° blades - Selection charts

DISTANCE BETWEEN CENTERS = (Flow Rate / 12 / Room Height)^{1/2}

Heating - 45° blades
Flow Rate / Pressure Drop / Air Speed / Noise Level

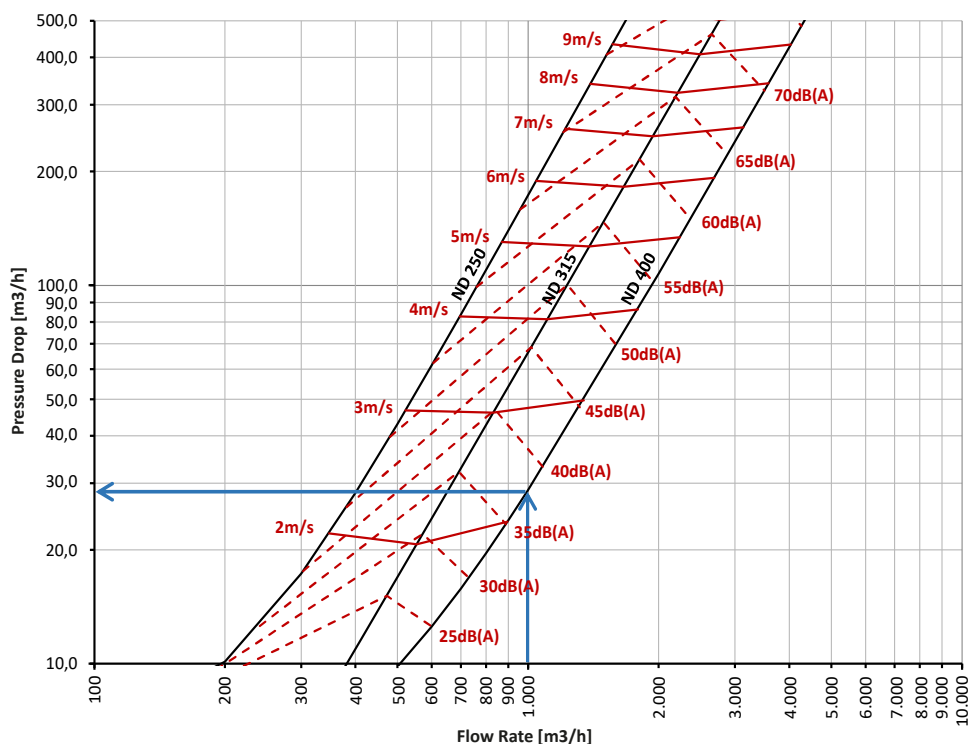

Heating - 45° blades
Flow Rate / Vertical Throw / Min. Installation Height

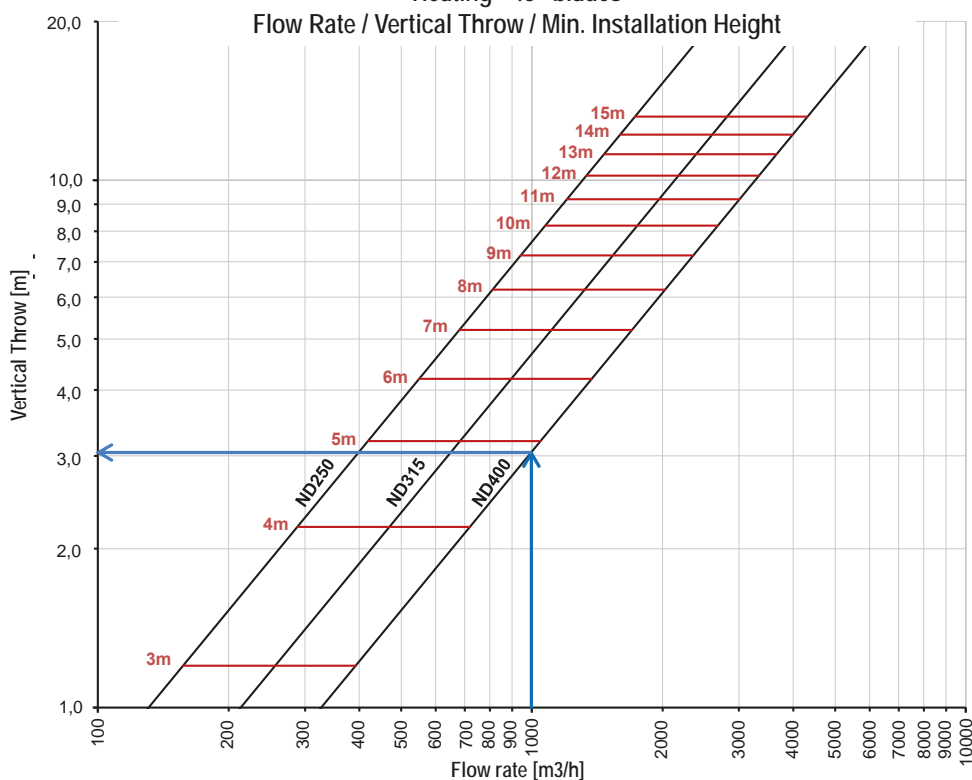

*on request

Diagram 1 Heating - 45° blades

The diagram shows the pressure drop of the diffuser based on the flow rate with relative indication of the noise level. Data referred to international standard atmosphere and measured according to the following regulations:

- ISO 5801:2017** Aerulic Performance
- ISO 5135:2020** Acoustic Performance
- ISO 3741:2010** Acoustic Performance

CALCULATION (input data)

Total Flow Rate	10.000 m ³ /h
Max. Noise Level	40dB(A)
Number of diffusers expected	10pz.
Throw	3,00m

SELECTION

Model	DSRQ 400
Flow Rate	1.000 m ³ /h
Pressure Drop	29Pa
Noise Level	38dB(A)
Vertical Isothermal Throw	+/- 3,0m
Air Inlet Speed	+/- 2,2m/s
Min. Installation Height	+/- 4,9m

Diagram 2 Heating - 45° blades

The diagram shows the vertical isothermal throw of the diffuser based on the flow rate with terminal speed (Vt) of 0,25m/s, in addition to the indication of the minimum recommended installation height. These data refer to the diffuser with blades at 45° for heating function.

Note:
all operating data refer to diffusers with equalizing grid.

Cooling function - 67,5° blades - Selection charts

DISTANCE BETWEEN CENTERS = (Flow Rate / 12 / Room Height)^{1/2}

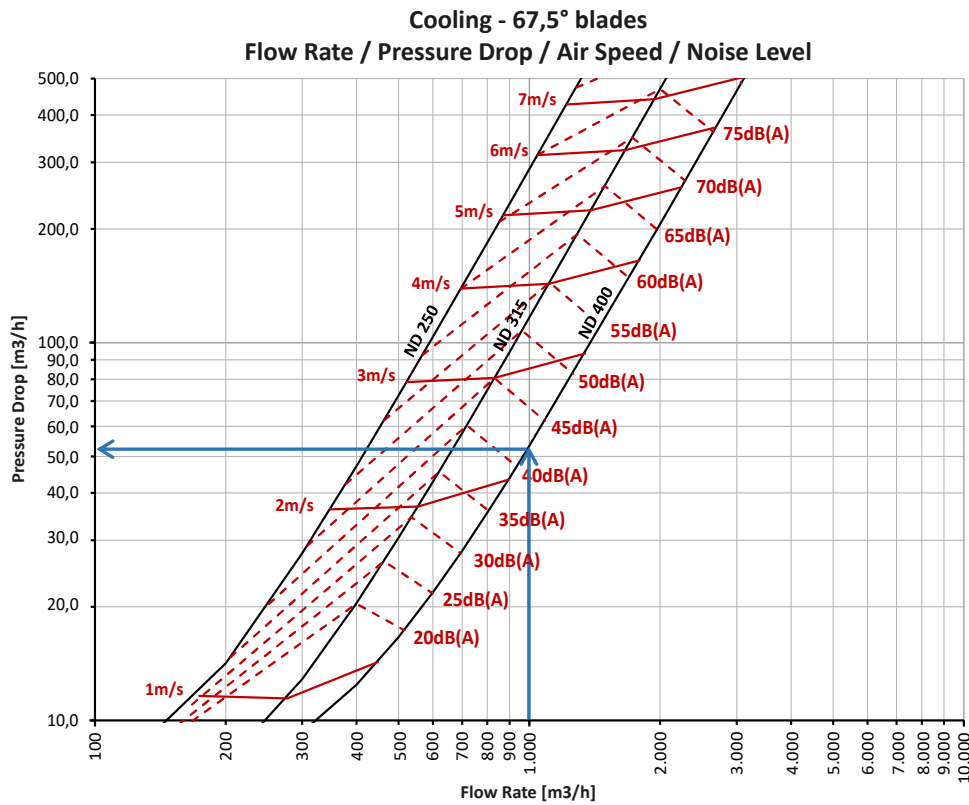

Diagram 3

Cooling – 67,5° blades

The diagram shows the pressure drop of the diffuser based on the flow rate with relative indication of the noise level.

Data referred to international standard atmosphere and measured according to the following regulations:

ISO 5801:2017	Aeraulic Performance
ISO 5135:2020	Acoustic Performance
ISO 3741:2010	Acoustic Performance

CALCULATION (input data)	
Total Flow Rate	10.000 m³/h
Max. Noise Level	45dB(A)
Number of diffusers expected	10pz.
Throw	0,75m

SELECTION	
Model	DSRQ 400
Flow Rate	1.000 m³/h
Pressure Drop	53Pa
Noise Level	42dB(A)
Vertical Isothermal Throw	+/- 0,75m
Air Inlet Speed	+/- 2,2m/s
Min. Installation Height	+/- 2,7m

Diagram 4

Cooling – 67,5° blades

The diagram shows the vertical isothermal throw of the diffuser based on the flow rate with terminal speed (Vt) of 0,25m/s, in addition to the indication of the minimum recommended installation height. These data refer to the diffuser with blades at 67,5° for cooling function.

Note:

all operating data refer to diffusers with equalizing grid.

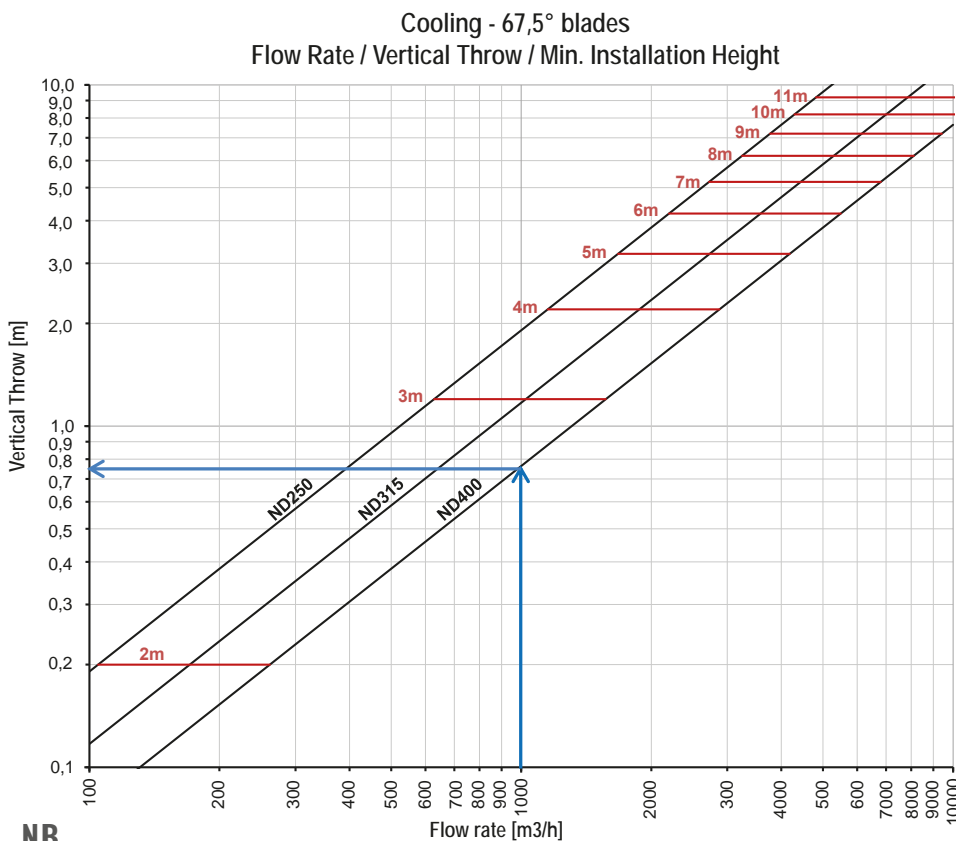

NB

- Pressure drop data shown in the diagram refer to the diffuser with the damper fully open.
- The data relating to the minimum installation height must be understood from the floor level. The air speed at the limit of the comfort zone (1,80m from the floor) is assumed equal to 0,25m/s.

HEATING - TABLE OF OPERATING DATA - 45° BLADES

MODEL	DESCRIPTION	U.M.	Vi (m/s)									
			1	2	3	4	5	6	7	8	9	10
250 Ak 0,04830m ²	Flow Rate	m3/h	174	348	522	696	869	1.043	1.217	1.391	1.565	1.739
	Pressure Drop 45° Blades - Heating	Pa	8,9	22,1	46,7	82,7	130,1	188,9	259,1	340,7	433,6	538,0
	Vertical Throw Vt 0,25 45° Blades - Heating	mt	1,3	2,7	4,0	5,3	6,6	8,0	9,3	10,6	12,0	13,3
	Noise Level 45° Blades - Heating	dB(A)	28	43	52	58	63	67	70	73	76	78
	Min. Installation Height	mt	3,1	4,5	5,8	7,1	8,4	9,8	11,1	12,4	13,8	15,1
315 Ak 0,07694m ²	Flow Rate	m3/h	277	554	831	1.108	1.385	1.662	1.939	2.216	2.493	2.770
	Pressure Drop 45° Blades - Heating	Pa	5,3	20,7	46,1	81,5	126,8	182,2	247,6	323,0	408,5	503,9
	Vertical Throw Vt 0,25 45° Blades - Heating	mt	1,3	2,6	3,9	5,2	6,5	7,8	9,1	10,4	11,7	13,0
	Noise Level 45° Blades - Heating	dB(A)	<20	29	40	47	53	58	62	65	68	71
	Min. Installation Height	mt	3,1	4,4	5,7	7,0	8,3	9,6	10,9	12,2	13,5	14,8
400 Ak 0,12441m ²	Flow Rate	m3/h	448	896	1.344	1.792	2.239	2.687	3.135	3.583	4.031	4.479
	Pressure Drop 45° Blades - Heating	Pa	8,6	23,7	49,7	86,4	134,1	192,5	261,8	341,9	432,9	534,7
	Vertical Throw Vt 0,25 45° Blades - Heating	mt	1,4	2,7	4,1	5,5	6,8	8,2	9,6	11,0	12,3	13,7
	Noise Level 45° Blades - Heating	dB(A)	<20	35	46	53	59	63	67	71	74	76
	Min. Installation Height	mt	3,2	4,5	5,9	7,3	8,6	10,0	11,4	12,8	14,1	15,5

COOLING - TABLE OF OPERATING DATA - 67,5° BLADES

MODEL	DESCRIPTION	U.M.	Vi (m/s)									
			1	2	3	4	5	6	7	8	9	10
250 Ak 0,04830m ²	Flow Rate	m3/h	174	348	522	696	869	1.043	1.217	1.391	1.565	1.739
	Pressure Drop 67,5° Blades - Cooling	Pa	11,6	36,2	78,7	139,1	217,4	313,5	427,6	559,5	709,4	877,1
	Vertical Throw Vt 0,25 67,5° Blades - Cooling	mt	0,3	0,7	1,0	1,3	1,7	2,0	2,3	2,7	3,0	3,3
	Noise Level 67,5° Blades - Cooling	dB(A)	31	48	58	65	70	75	79	82	85	88
	Min. Installation Height	mt	3,1	4,5	5,8	7,1	8,4	9,8	11,1	12,4	13,8	15,1
315 Ak 0,07694m ²	Flow Rate	m3/h	277	554	831	1.108	1.385	1.662	1.939	2.216	2.493	2.770
	Pressure Drop 67,5° Blades - Cooling	Pa	11,4	36,8	80,7	143,1	223,9	323,3	441,2	577,5	732,4	905,7
	Vertical Throw Vt 0,25 67,5° Blades - Cooling	mt	0,3	0,6	1,0	1,3	1,6	1,9	2,3	2,6	2,9	3,2
	Noise Level 67,5° Blades - Cooling	dB(A)	<20	31	45	55	62	69	74	79	83	86
	Min. Installation Height	mt	3,1	4,4	5,7	7,0	8,3	9,6	10,9	12,2	13,5	14,8
400 Ak 0,12441m ²	Flow Rate	m3/h	448	896	1.344	1.792	2.239	2.687	3.135	3.583	4.031	4.479
	Pressure Drop 67,5° Blades - Cooling	Pa	14,3	43,5	93,8	165,3	257,9	371,7	506,7	662,8	840,1	1.038,6
	Vertical Throw Vt 0,25 67,5° Blades - Cooling	mt	0,3	0,7	1,0	1,4	1,7	2,1	2,4	2,7	3,1	3,4
	Noise Level 67,5° Blades - Cooling	dB(A)	<20	39	52	62	69	75	81	85	89	93
	Min. Installation Height	mt	3,2	4,5	5,9	7,3	8,6	10,0	11,4	12,8	14,1	15,5

Data referring to atm. stands - measured according to: ISO 5801:2017 Aeracoustic Performance / ISO 5135:2020 Acoustic Performance / ISO 3741:2010 Acoustic Performance | Note: the data indicated refer to operation in isothermal conditions