



DSRS-Therm

Variable geometry diffuser developed for rooms with high ceilings where a long throw and a high induction ratio are required. Made up of a housing in which simultaneously adjustable deflectors are equipped with a thermostatic system in order to change the air flow direction according to the required thermal conditions.

TECHNICAL SPECIFICATION AND USAGE LIMIT

INSTALLATION HEIGHT	APPLICATIONS	MAIN BELL MATERIAL	BLADES MATERIAL	SURFACE FINISH	COLOR	FASTENING
up to 16 m	Room cooling and heating	Aluminum	Galvanized Steel	Epoxy powder coating resistant to impact and abrasion	Standard RAL 9010 - glossy RAL 9016 - glossy RAL 9003 - mat	by means of screws positioned on the diffuser neck

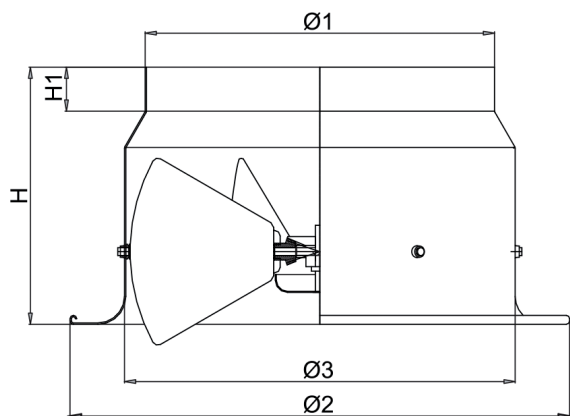

Note:
All DSRS Therm models are equipped with an equalizing grid.

GREEN BUILDING

Thanks also to the support of GreenMap, products manufactured by Tecnica srl contribute to obtain the credits of the major international rating systems for sustainable buildings:



LEED

Contributes to credits:
IP, EA, MR, EQ



WELL

Contributes to credits:
THERMAL COMFORT,
MATERIALS, COMMUNITY

BREEAM

BREEAM









Contributes to credits:
MAN, HEA, WST

For further details about specific contributions to the credits indicated, contact Tecnica Srl

TECHNICAL DATA

Model	Ø 1 [mm]	Ø 2 [mm]	Ø 3 [mm]	Ø Foro [mm]	H [mm]	H1 [mm]
DSR 250	248	393	283	340	200	40
DSR 315	313	458	348	400	230	40
DSR 400	398	563	437	500	260	60
DSR 500	498	683	540	630	280	60
DSR 630	628	803	675	760	325	70

APPLICATIONS

								
Residential	Easy Pack	Calculation Method	REACH Certificat	RoHS Certificat	Industry	Building	Air Conditioning	Interior design

Heating function - 45° blades - Selection charts

DISTANCE BETWEEN CENTERS = (Flow Rate / 12 / Room Height)^{1/2}

*on request

Diagram 1 Heating – 45° blades

The diagram shows the pressure drop of the diffuser based on the flow rate with relative indication of the noise level without environmental attenuation and speed of the incoming air flow. These data refer to the diffuser with blades at 45° for heating function.

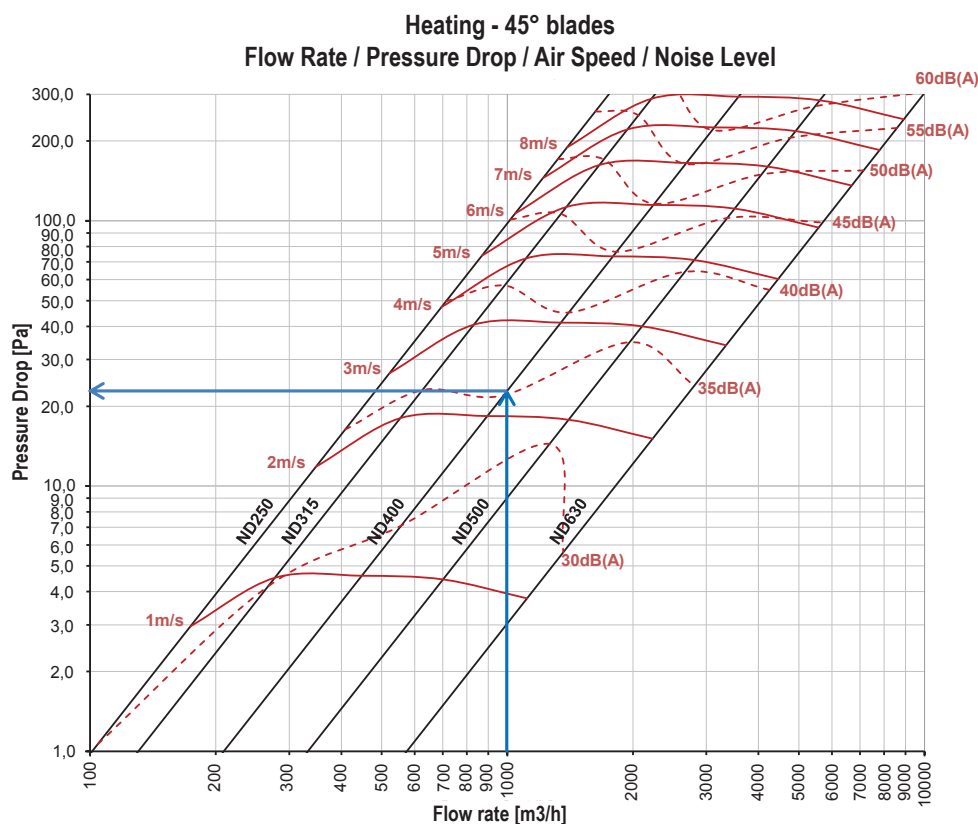

CALCULATION (input data)	
Total Flow Rate	10.000 m ³ /h
Max. Noise Level	35dB(A)
Number of diffusers expected	10pz.
Throw	3,00m

SELECTION	
Model	DSR 400
Flow Rate	1.000 m ³ /h
Pressure Drop	+/- 25Pa
Noise Level	+/- 35dB(A)
Vertical Isothermal Throw	+/- 3,0m
Air Inlet Speed	+/- 2,2m/s
Min. Installation Height	+/- 4,9m

Diagram 2 Heating – 45° blades

The diagram shows the vertical isothermal throw of the diffuser based on the flow rate with terminal speed (Vt) of 0,25m/s, in addition to the indication of the minimum recommended installation height. These data refer to the diffuser with blades at 45° for heating function.

Note:
all operating data refer to diffusers with equalizing grid.

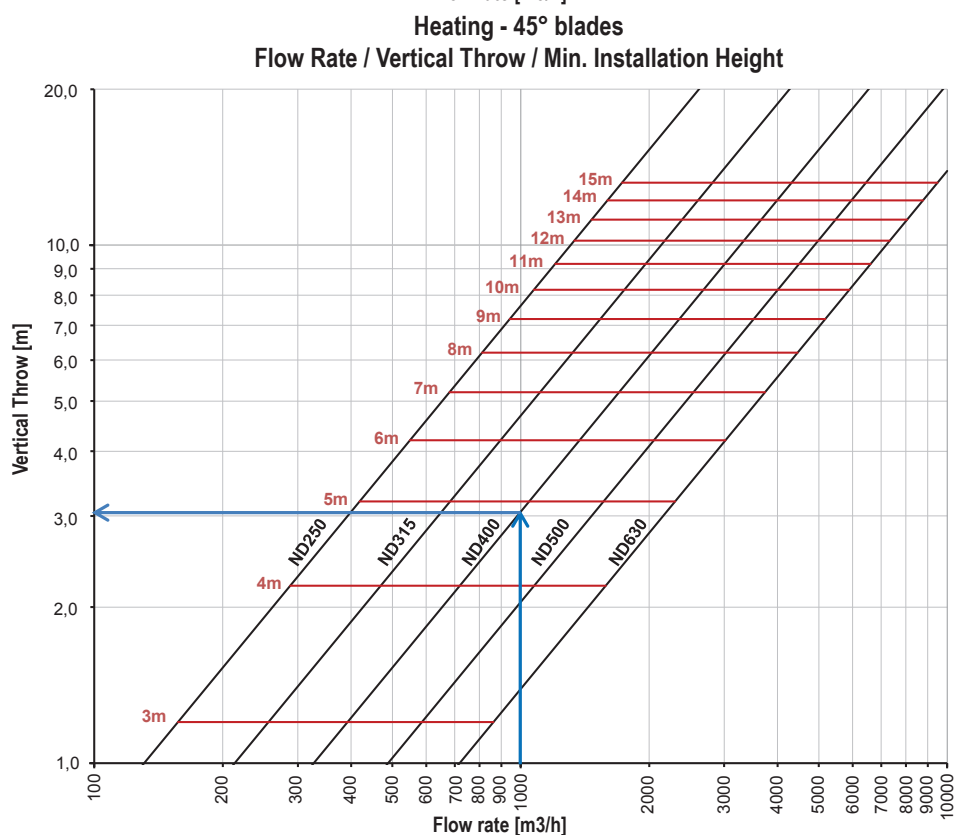

HEATING - TABLE OF OPERATING DATA - 45° BLADES

MODEL	DESCRIPTION	U.M.	Vi (m/sec)									
			1	2	3	4	5	6	7	8	9	10
250 Ak: 0,04831m ²	Flow Rate	m ³ /h	174	348	522	696	869	1043	1217	1391	1565	1739
	Pressure Drop 45° Blades - Heating	Pa	3,0	11,8	26,6	47,3	73,9	106,5	144,9	189,3	239,6	295,8
	Vertical Throw Vt 0,25 45° Blades - Heating	mt	1,3	2,7	4,0	5,3	6,6	8,0	9,3	10,6	12,0	13,3
	Noise Level 45° Blades - Heating	dB(A)	32	34	37	40	43	46	49	52	54	57
	Min. Installation Height	mt	3,1	4,5	5,8	7,1	8,4	9,8	11,1	12,4	13,8	15,1
315 Ak: 0,07694m ²	Flow Rate	m ³ /h	277	554	831	1108	1385	1662	1939	2216	2493	2770
	Pressure Drop 45° Blades - Heating	Pa	4,5	18,0	40,6	72,1	112,7	162,3	220,9	288,6	365,2	450,9
	Vertical Throw Vt 0,25 45° Blades - Heating	mt	1,3	2,6	3,9	5,2	6,5	7,8	9,1	10,4	11,7	13,0
	Noise Level 45° Blades - Heating	dB(A)	30	34	38	42	46	49	53	57	61	65
	Min. Installation Height	mt	3,1	4,4	5,7	7,0	8,3	9,6	10,9	12,2	13,5	14,8
400 Ak: 0,12441m ²	Flow Rate	m ³ /h	448	896	1344	1792	2239	2687	3135	3583	4031	4479
	Pressure Drop 45° Blades - Heating	Pa	4,6	18,4	41,3	73,4	114,8	165,2	224,9	293,8	371,8	459,0
	Vertical Throw Vt 0,25 45° Blades - Heating	mt	1,4	2,7	4,1	5,5	6,8	8,2	9,6	11,0	12,3	13,7
	Noise Level 45° Blades - Heating	dB(A)	29	34	39	45	50	55	60	66	71	76
	Min. Installation Height	mt	3,2	4,5	5,9	7,3	8,6	10,0	11,4	12,8	14,1	15,5
500 Ak: 0,19478m ²	Flow Rate	m ³ /h	701	1402	2104	2805	3506	4207	4909	5610	6311	7012
	Pressure Drop 45° Blades - Heating	Pa	4,4	17,8	40,0	71,1	111,2	160,1	217,9	284,5	360,1	444,6
	Vertical Throw Vt 0,25 45° Blades - Heating	mt	1,4	2,9	4,3	5,7	7,2	8,6	10,0	11,5	12,9	14,4
	Noise Level 45° Blades - Heating	dB(A)	26	31	36	41	46	51	56	61	66	71
	Min. Installation Height	mt	3,2	4,7	6,1	7,5	9,0	10,4	11,8	13,3	14,7	16,2
630 Ak: 0,30975m ²	Flow Rate	m ³ /h	1115	2230	3345	4460	5575	6691	7806	8921	10036	11151
	Pressure Drop 45° Blades - Heating	Pa	3,8	15,1	34,0	60,4	94,3	135,8	184,9	241,4	305,6	377,2
	Vertical Throw Vt 0,25 45° Blades - Heating	mt	1,6	3,1	4,7	6,2	7,8	9,3	10,9	12,4	14,0	15,5
	Noise Level 45° Blades - Heating	dB(A)	29	33	37	41	45	48	52	56	60	64
	Min. Installation Height	mt	3,4	4,9	6,5	8,0	9,6	11,1	12,7	14,2	15,8	17,3

Note: the data indicated refer to operation in isothermal conditions

Cooling function - 67,5° blades - Selection charts
DISTANCE BETWEEN CENTERS = (Flow Rate / 12 / Room Height)^{1/2}

Cooling - 67,5° blades
Flow Rate / Pressure Drop / Air Speed / Noise Level

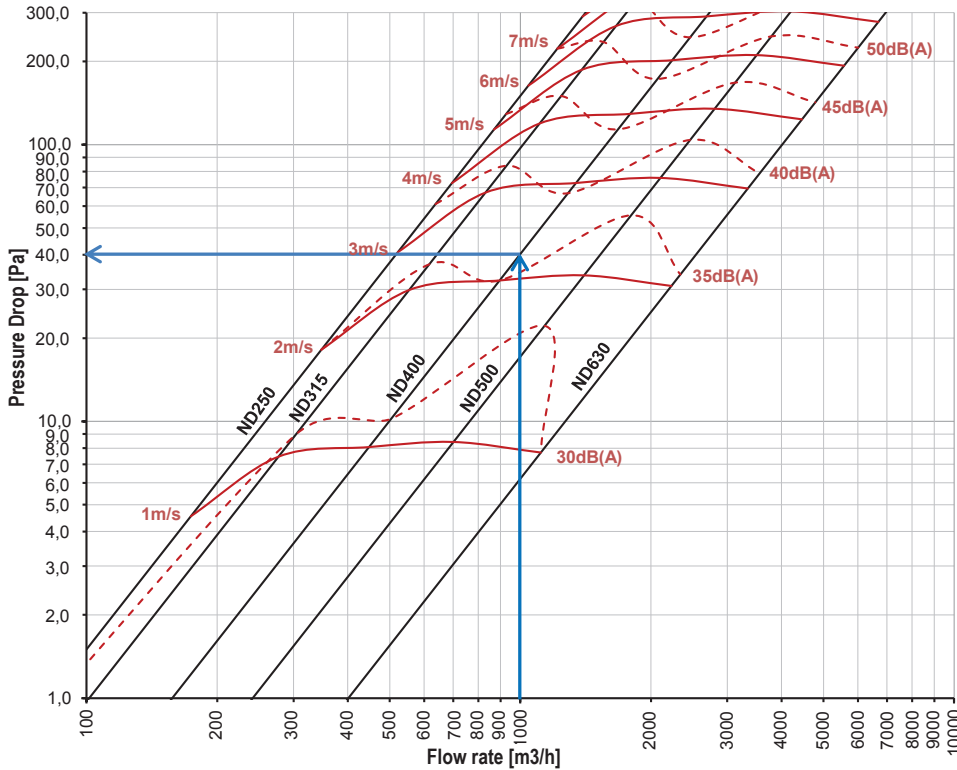

Cooling - 67,5° blades
Flow Rate / Vertical Throw / Min. Installation Height

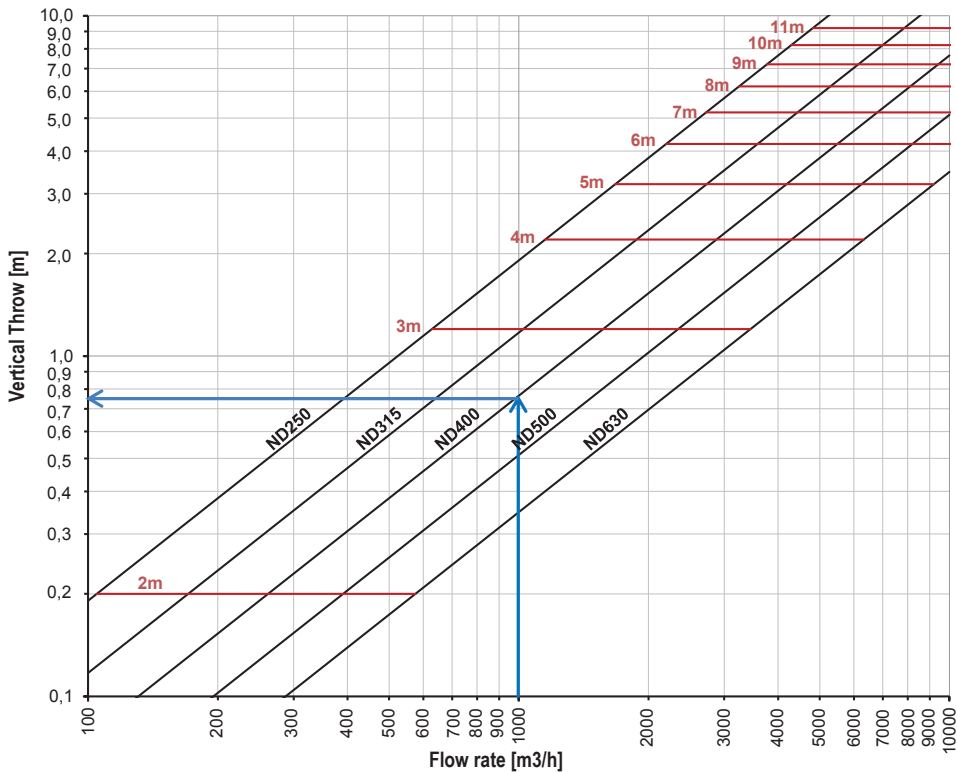

Note

- Pressure drop data shown in the diagram refer to the diffuser with the damper fully open.
- The data relating to the minimum installation height must be understood from the floor level. The air speed at the limit of the comfort zone (1,80m from the floor) is assumed equal to 0,25m/s.

Diagram 3
Cooling – 67,5° blades

The diagram shows the pressure drop of the diffuser based on the flow rate with relative indication of the noise level without environmental attenuation and speed of the incoming air flow. These data refer to the diffuser with blades at 67,5° for cooling function.

CALCULATION (input data)	
Total Flow Rate	10.000 m ³ /h
Max. Noise Level	37dB(A)
Number of diffusers expected	10pz.
Throw	0,75m

SELECTION	
Model	DSR 400
Flow Rate	1.000 m ³ /h
Pressure Drop	+/- 40Pa
Noise Level	37dB(A)
Vertical Isothermal Throw	+/- 0,75m
Air Inlet Speed	+/- 2,2m/s
Min. Installation Height	+/- 2,7m

Diagram 4
Cooling – 67,5° blades

The diagram shows the vertical isothermal throw of the diffuser based on the flow rate with terminal speed (Vt) of 0,25m/s, in addition to the indication of the minimum recommended installation height. These data refer to the diffuser with blades at 67,5° for cooling function.

Note:

all operating data refer to diffusers with equalizing grid.

COOLING - TABLE OF OPERATING DATA - 67,5° BLADES

MODEL	DESCRIPTION	U.M.	Vi (m/sec)									
			1	2	3	4	5	6	7	8	9	10
250 Ak: 0,04831m ²	Flow Rate	m ³ /h	174	348	522	696	869	1043	1217	1391	1565	1739
	Pressure Drop 67,5° Blades - Heating	Pa	4,5	18,2	40,9	72,6	113,5	163,4	222,5	290,6	367,7	454,0
	Vertical Throw Vt 0,25 67,5° Blades - Heating	mt	0,3	0,7	1,0	1,3	1,7	2,0	2,3	2,7	3,0	3,3
	Noise Level 67,5° Blades - Heating	dB(A)	32	35	38	41	44	47	50	53	56	59
	Min. Installation Height	mt	3,1	4,5	5,8	7,1	8,4	9,8	11,1	12,4	13,8	15,1
315 Ak: 0,07694m ²	Flow Rate	m ³ /h	277	554	831	1108	1385	1662	1939	2216	2493	2770
	Pressure Drop 67,5° Blades - Heating	Pa	7,5	29,8	67,1	119,3	186,4	268,5	365,4	477,3	604,1	745,7
	Vertical Throw Vt 0,25 67,5° Blades - Heating	mt	0,3	0,6	1,0	1,3	1,6	1,9	2,3	2,6	2,9	3,2
	Noise Level 67,5° Blades - Heating	dB(A)	30	34	38	43	47	52	56	61	65	69
	Min. Installation Height	mt	3,1	4,4	5,7	7,0	8,3	9,6	10,9	12,2	13,5	14,8
400 Ak: 0,12441m ²	Flow Rate	m ³ /h	448	896	1344	1792	2239	2687	3135	3583	4031	4479
	Pressure Drop 67,5° Blades - Heating	Pa	8,1	32,3	72,7	129,2	201,9	290,8	395,8	516,9	654,2	807,7
	Vertical Throw Vt 0,25 67,5° Blades - Heating	mt	0,3	0,7	1,0	1,4	1,7	2,1	2,4	2,7	3,1	3,4
	Noise Level 67,5° Blades - Heating	dB(A)	29	35	41	46	52	58	64	69	75	81
	Min. Installation Height	mt	3,2	4,5	5,9	7,3	8,6	10,0	11,4	12,8	14,1	15,5
500 Ak: 0,19478m ²	Flow Rate	m ³ /h	701	1402	2104	2805	3506	4207	4909	5610	6311	7012
	Pressure Drop 67,5° Blades - Heating	Pa	8,4	33,7	75,8	134,8	210,7	303,4	412,9	539,3	682,6	842,7
	Vertical Throw Vt 0,25 67,5° Blades - Heating	mt	0,4	0,7	1,1	1,4	1,8	2,2	2,5	2,9	3,2	3,6
	Noise Level 67,5° Blades - Heating	dB(A)	27	32	37	43	48	53	58	64	69	74
	Min. Installation Height	mt	3,2	4,7	6,1	7,5	9,0	10,4	11,8	13,3	14,7	16,2
630 Ak: 0,30975m ²	Flow Rate	m ³ /h	1115	2230	3345	4460	5575	6691	7806	8921	10036	11151
	Pressure Drop 67,5° Blades - Heating	Pa	7,7	30,9	69,5	123,5	192,9	277,8	378,1	493,9	625,1	771,7
	Vertical Throw Vt 0,25 67,5° Blades - Heating	mt	0,4	0,8	1,2	1,6	1,9	2,3	2,7	3,1	3,5	3,9
	Noise Level 67,5° Blades - Heating	dB(A)	30	35	39	44	48	53	57	62	66	71
	Min. Installation Height	mt	3,4	4,9	6,5	8,0	9,6	11,1	12,7	14,2	15,8	17,3

i Note: the data indicated refer to operation in isothermal conditions

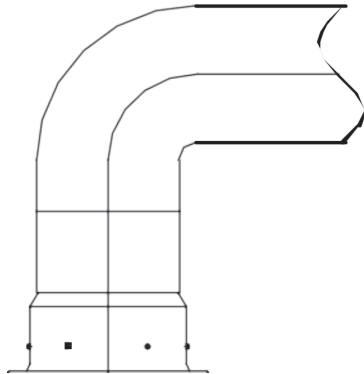

FIG. 1 INSTALLATION ON METAL ELBOW WITH CONNECTING SLEEVE

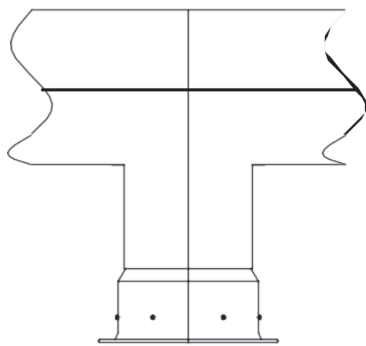

FIG. 2 INSTALLATION ON DUCT WITH CONNECTING SLEEVE

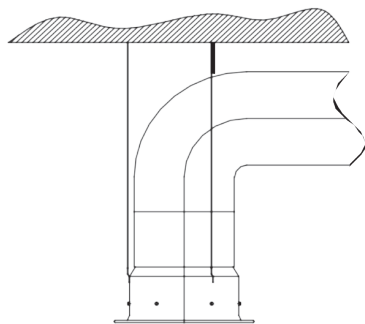

FIG. 3 INSTALLATION ON FLEXIBLE HOSE

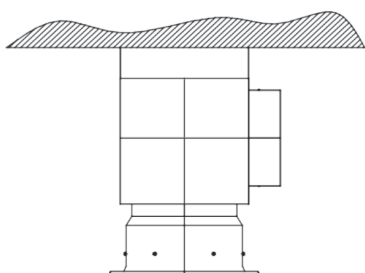

FIG. 4 INSTALLATION WITH PLENUM

Thermostatic System Detail

The self-adjusting system for blades is made with harmonic steel springs with a thermostatic effect which allow to correctly relocate the blades of the diffuser based on the temperature of the air introduced to obtain the appropriate throw.

Easy installation, adjustments and maintenance. The internal deflectors are easy to adjust: in the version with manual adjustment of each single component; in the version with simultaneous adjustment by acting on the central adjustment screw. The version with simultaneous adjustment can be motorized.

Adjustment

Deflector positioned at an angle greater than 45° (closing): optimal position in cooling conditions in order to have the largest horizontal diffusion radius without creating discomfort in the occupied area.

Deflector positioned at an angle smaller than 45° (opening): optimal position for particularly high rooms and in heating conditions, as you obtain a vertical downward throw that resists the convective motion of the ambient air.

Models

DSR: variable geometry diffuser on round base with manual adjustment.

DSR-S: variable geometry diffuser on round base with simultaneous adjustment.

Fig. 1 Installation on elbow and connecting sleeve

- Fasten the diffuser neck on the connecting sleeve by means of screws with a distance of at least one diameter. Fasten the sleeve to the metal elbow.
- Adjust the deflectors according to the desired diffusion parameters.

Fig. 2 Installation on duct with connecting sleeve

- Fasten the diffuser neck on the connecting sleeve by means of screws with a distance of at least one diameter.
- Fasten the sleeve to the metal duct.
- Adjust the deflectors according to the desired diffusion parameters.

Fig 3 Installation on flexible hose

- Hang the diffuser on the ceiling or fasten it on the false ceiling.
- Fit the flexible duct on the diffuser neck and fasten it with a hose clamp.
- Adjust the deflectors according to the desired diffusion parameters.

Fig. 4 Installation with plenum

- Fasten the plenum to the ceiling by means of brackets.
- Adjust the damper.
- Fasten the diffuser to the plenum outlet sleeve by means of screws.
- Fit the flexible duct on the plenum inlet sleeve.
- Adjust the deflectors according to the desired diffusion parameters.